



## ***New Gi Generator for Groundwater Remediation***

### **ABSTRACT**

**The Gi Generator, a patented mass-transfer device from inVentures Technologies, Inc. of Canada has been used in aquaculture for years. The equipment has been adapted for in-situ remediation projects. For aerobic bioremediation of hydrocarbons, MTBE, TBA, vinyl chloride, or the precipitation of certain metals (such as arsenic), large volumes of high concentration dissolved oxygen can be used. Many chlorinated solvents such as PCE and TCE, as well as other chemicals such as perchlorate, or the precipitation of certain metals (such as chromium or uranium) require anaerobic processes. These processes can occur with the introduction of dissolved hydrogen, methane, propane, butane, or other gases. Other co-metabolic pathways remediation pathways are also available.**

### **Follow-Up to iSOC<sup>®</sup> Success**

iSOC<sup>®</sup> (in-situ Submerged Oxygen Curtain) has set the standard for enhancement of groundwater remediation through natural attenuation. iSOC<sup>®</sup> is a gas delivery system, based on inVenture's patented *Gas inFusion* technology, that will infuse any gas into a liquid. iSOC<sup>®</sup> is passive in nature with no moving parts and requiring little or no O&M. The technology is very inexpensive to install and operate, and can be easily moved to a new injection point or new site. Currently, iSOC<sup>®</sup> installations are working successfully on more than 450 sites throughout the world.

In addition to the addition of oxygen being proven effective in the enhancement of biodegradation of hydrocarbon related compounds, the iSOC<sup>®</sup> *Gas inFusion* technology is also effective in the infusion of any gas into groundwater. The controlled addition of gases such as hydrogen, methane and propane to groundwater has been successfully

used to enhance the natural attenuation of chlorinated solvents such as TCE and PCE. The table below illustrates potential dissolved gas concentrations for five gases based on water column of different depths.

Gas Type	Water Column Depth in Feet				
	5'	10'	15'	20'	50'
Oxygen	42	55	62	69	111
Methane	22	30	33	37	59
Propane	66	88	99	110	175
Hydrogen	2	2	3	3	5
Ethane	57	75	85	95	150

**iSOC<sup>®</sup> Dissolved Gas Concentrations (mg/l) in a Water Column**

**Gi Generator**

The *Gi Generator*, also based on the well-proven *Gas inFusion* technology, infuses significantly higher dissolved gas concentrations in groundwater, unattainable with any other technology. Like the technology itself, the *Gi Generator* is simple, small in size, easy to operate, and requires little to no O&M. All that is required for operation setup is three connections: an oxygen or other gas supply, a pressurized water supply, and the discharge connection. Once connected, and the valves opened, the unique but simple *Gi Generator* control system automatically operates the system according to the pressure and flow rate of both water and oxygen (or other gas), and the dissolved oxygen (or other gas) demand. Like iSOC<sup>®</sup>, setup and operation are quick and easy.

Similar *Gi Generators* have been successfully used in several other market applications including aquaculture, hydroponics and industrial processes. inVentures has tested and continues testing *Gi Generators* in two groundwater remediation applications in association with the University of Waterloo—accelerated biodegradation of dissolved hydrocarbons through super oxygenation, and a proprietary DNAPL recovery process.

**The Gi Process**

*Gi Generation* is made up of two essential parts: *Gi* production, and *Gi* delivery. As illustrated below, in *Gi* production, oxygen fills the Microporous hollow fiber inside the *Gi Generator Gas inFusion* devices, while the pressurized water flows past this fiber. The highly efficient mass transfer process dissolves large amounts of oxygen in the water under pressure, typically 25 to 250 mg/l of DO depending on pressure and flow conditions desired for specific applications. The DO levels can be adjusted to suit client needs.

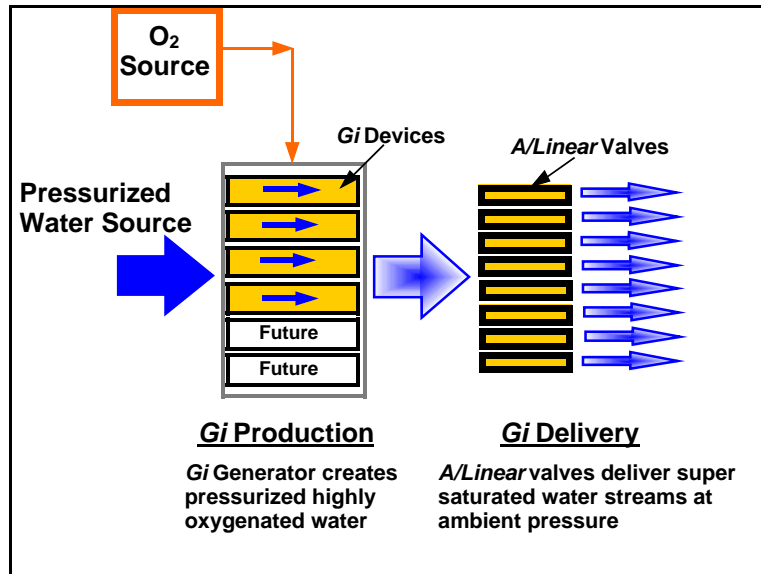

**Gi Generator Process**

*Gi* delivery involves another proprietary iTi invention, called the *A/Linear* valve, which uses hollow fiber to relieve the pressure of the highly oxygenated production stream such that essentially all of the dissolved oxygen is maintained in a virtually bubble-less form at ambient pressure. Any bubbles present are typically less than 50 microns in size. This unique, patented production and delivery process creates a supersaturated stream containing hundreds of PPM of dissolved oxygen, depending on flow conditions. This dissolved oxygen does not degrade like conventional processes, but remains in solution significantly longer for biological consumption. No other technology or process in the world can equal this.

## Gi Generator Performance

The oxygen transfer per *Gi Generator* is controlled by water flow rate, feed water pressure, and the size of *A/Linear* valve used. The performance chart and data table illustrate this varying performance. inVentures is capable of modeling *Gi Generator* systems to meet specific site remediation needs.

*Gi Generation* is elegant in its simplicity. Start up is achieved by opening valves. That's it. Control is automatic, and again, simple. If the water supply, or oxygen supply, is interrupted, the system shuts down, and waits for pressure to be re-established, which again achieves full operation automatically.

## Gi Operations

Pressurized water must be supplied to the unit. The *Gi Generator* is capable of operating on groundwater feed. Considerations for the re-injection well are paramount as high iron conditions will not affect the *Gi Generator* but may cause problems with the wells.

Environmental Bio-Systems, Inc., [www.ebsinfo.com](http://www.ebsinfo.com) tel: 415-381-5195; augerpro@sbcglobal.net

As earlier stated, the oxygen concentration exiting the unit will depend upon the water feed rate and the feed pressure. At low water rates the exiting water will be at or near saturation at the operating pressure. At higher water feed rates, the oxygen concentration will level out at approximately 25-35% of saturation at operating pressure. For example, at an operating pressure of 30 psig, the oxygen saturation is approximately 135 mg/l, depending on the temperature. Low water rates would mean ~ 135 mg/l oxygen in the water leaving the unit. High water rates would mean ~ 34-47 mg/l of oxygen leaving the unit. The water exiting the unit is under pressure.

The Gi process can operate without iTi's *A/Linear valves* if the wellhead is sealed. inVentures feels the need for more experience with this method (which we are gaining with our work with Waterloo) and we do not recommend using it at this time. In the meantime, each *A/Linear valve* will need to be connected to the outlet of the unit by polyurethane tubing to reach the bottom of each well.

The small size of the *Gi Generator* equipment allows a trailer or truck-mounted setup to be used to move from one set of injection points to another on the same site. For permanent setups, the unit can be housed in an extremely small shed or in a ground vault similar to those used for transformers. A unit capable of oxygenating 75 USGPM and transferring approximately 28 lbs. of oxygen into will have an oxygen concentration of approximately 35 mg/l depending upon the initial concentration of the inlet water. The actual size of the unit is approximately 24" by 40" by 48" tall. Power requirements are a 3 HP pump.

### Gi Generator Schematic

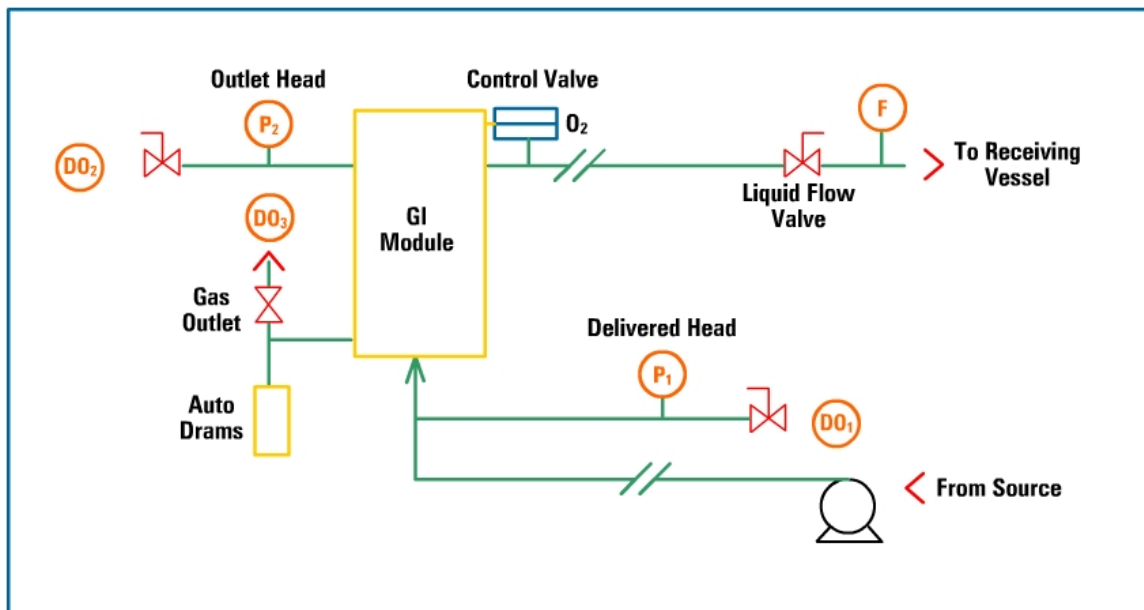

$DO_1$  = the dissolved oxygen content in the influent fluid

$DO_2$  = the dissolved oxygen content in the exiting fluid

$DO_3$  = the dissolved oxygen within the system

$P_1$  = pressure of the incoming fluid

$P_2$  = pressure of the fluid leaving system =  $P_1$  less system head losses

## **Total Number of Injection Points**

The *Gi Generator* discharge lines and *A/Linear valves* can be connected to a header allowing multiple injection points. Current design provides for a 0 to 10 GPM total flow rate through each *A/Linear valve*.

*A/Linear valves* are iTi's specially designed valves which allow the pressure of the water to be reduced in such a manner as to cause an absolute minimum of turbulence, and thereby minimize bubble formation and retain almost all of the oxygen in a dissolved state, even though the water exiting the valve is (thermodynamically) supersaturated. The outer casing of these valves is made from 1/2" PVC pipe and therefore fit easily down to the bottom of an injection well and allows the use of injection wells as small as 1-inch in diameter.

*A/Linear valves* can be manufactured by iTi in a variety of sizes (capacities). We will need some indication of the throughput the customer wishes to have and at what pressures—upstream of the valve, the generator operating pressure, downstream of the valve, and the head pressure at the bottom of the well.

The valves design allows easy change out, so a variety of sizes can be used according to the specific needs of the remediation system and the size of the injection wells.

## **Gi Generation Advantages**

The demonstrated advantages of *Gi Generation* include:

- More efficient mass transfer
- Higher dissolved oxygen levels at ambient pressure
- Reduced or virtually eliminated oxygen losses
- Lower power consumption
- Easily controlled
- Increased chemical and biological reaction rates
- Lower installation costs
- Use of 1-inch diameter injection wells
- Ability to move small, mobile unit around a remediation site

## MORE INFORMATION

[www.gasinfusion.com](http://www.gasinfusion.com)

[www.isocinfo.com](http://www.isocinfo.com)

[www.EBSinfo.com](http://www.EBSinfo.com)

For more information, please contact:



**James A. Jacobs, P.G., C.H.G.**  
**President**  
**Environmental Bio-Systems, Inc.**  
**707 View Point Road**  
**Mill Valley, CA 94941**  
**Tel: 415-381-5195**  
**Fax: 415-381-5816**  
**Email: [augerpro@sbcglobal.net](mailto:augerpro@sbcglobal.net)**

110105